

LL-504BGC2E-G3-1DC

DATA SHEET

QC:

ENG:

Prepared By:

Features

- ◆ High intensity
- ◆ Standard T-1 3/4 diameter package
- ◆ Wide viewing angle
- ◆ General purpose leads
- ◆ Reliable and rugged

Package Dimension:

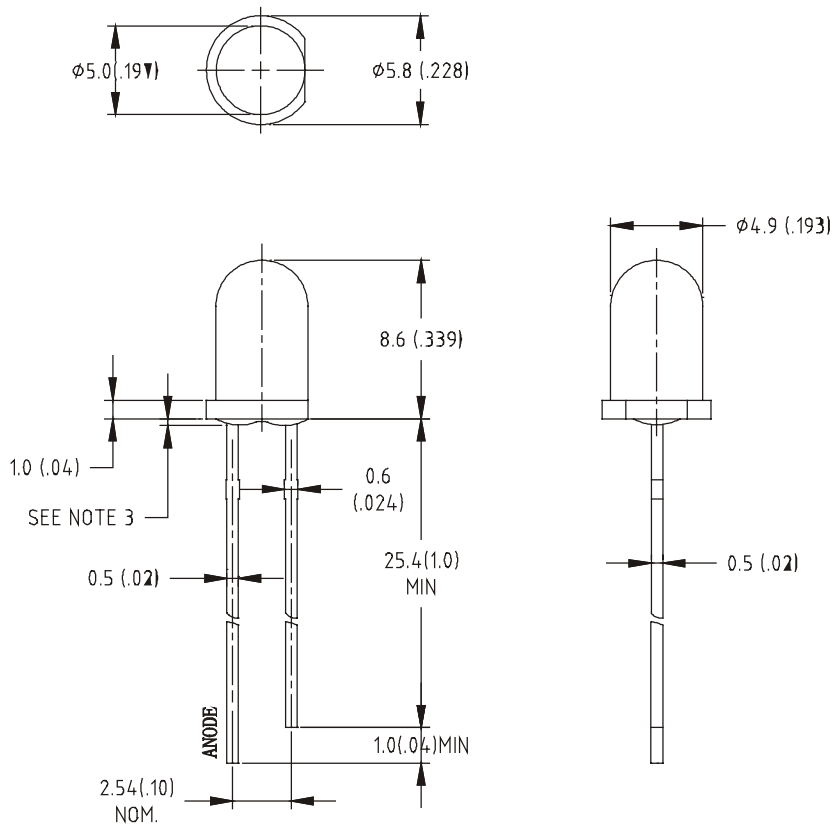

Part NO.	Chip Material	Lens Color	Source Color
LL-504BGC2E-G3-1DC	InGaN/SiC	Water Clear	Super Bright Blue Green

Notes:

1. All dimensions are in millimeters (inches).
2. Tolerance is $\pm 0.25 (.010)$ mm unless otherwise noted.
3. Protruded resin under flange is $1.0 \text{mm} (.04)$ max.
4. Lead spacing is measured where the leads emerge from the package.
5. Specifications are subject to change without notice.
6. Caution in ESD:
 Static Electricity and surge damages the LED. It is recommend to use a wrist band or anti-electrostatic glove when handling the LED. All devices, equipment and machinery must be properly grounded.

Absolute Maximum Ratings at Ta=25°C

Parameter	MAX.	Unit
Power Dissipation	100	mW
Peak Forward Current (1/10 Duty Cycle, 0.1ms Pulse Width)	100	mA
Continuous Forward Current	35	mA
Derating Linear From 50°C	0.4	mA/°C
Reverse Voltage	5	V
Operating Temperature Range	-40°C to +80°C	
Storage Temperature Range	-40°C to +80°C	
Lead Soldering Temperature [4mm(.157") From Body]	260°C for 5 Seconds	

Electrical Optical Characteristics at Ta=25°C

Parameter	Symbol	Min.	Typ.	Max.	Unit	Test Condition
Luminous Intensity	I _v	7000	9000	---	mcd	I _F =20mA (Note 1)
Viewing Angle	2θ _{1/2}	---	20	25	Deg	(Note 2)
Peak Emission Wavelength	λ _p	---	505	---	Nm	I _F =20mA
Dominant Wavelength	λ _d	495	505	515	Nm	I _F =20mA (Note 3)
Spectral Line Half-Width	Δλ	---	30	---	Nm	I _F =20mA
Forward Voltage	V _F	2.8	3.6	4.0	V	I _F =20mA
Reverse Current	I _R	---	---	10	μA	V _R =5V

Note:

1. Luminous intensity is measured with a light sensor and filter combination that approximates the CIE eye-response curve.
2. θ_{1/2} is the off-axis angle at which the luminous intensity is half the axial luminous intensity.
3. The dominant wavelength (λ_d) is derived from the CIE chromaticity diagram and represents the single wavelength which defines the color of the device.

Typical Electrical / Optical Characteristics Curves
 (25°C Ambient Temperature Unless Otherwise Noted)

Spectral Radiance Peak @ 505nm

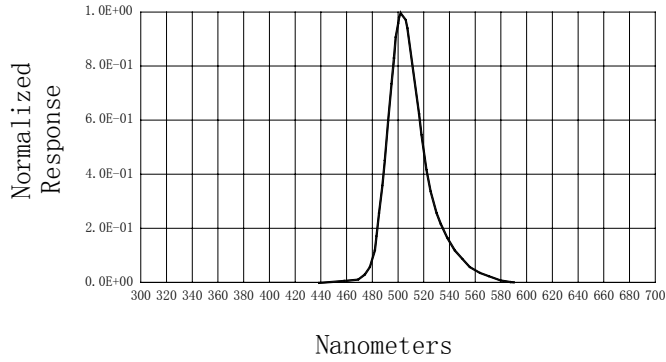

Relative Luminous Intensity vs Forward Current

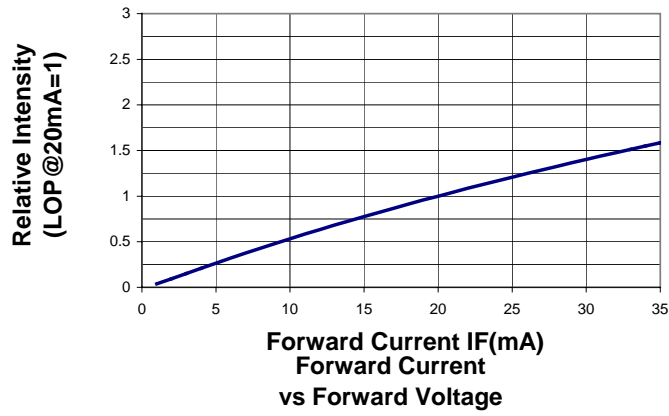

Forward Current vs Forward Voltage

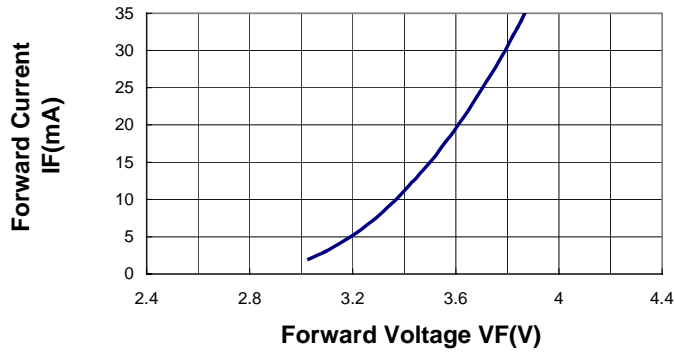

Beam Pattern

